

# Machine Qualification



## Understanding Machine Tool Calibration Systems



As a machine tool user or builder you need control and peace of mind, knowing that your machine is continuously **performing within required tolerances.**

# Understanding Machine Qualification



Innovative machine tools need state-of-the-art ultraprecise measuring equipment. **IBS's machine tool qualification systems** qualify and improve the geometrical and dynamic accuracy performance of linear axis, rotary axis and spindles.



## Methods of machine qualification

Our measuring system **based on sensor technology** is the only tool that can **perform a 3D dynamic measurement** in conformity with the ISO standard in just a minute. In contrast, alternative measuring methods such as touch probes are static and therefore unable to measure dynamic errors.

Additionally, these alternatives are limited to 1-dimensional measurements, making them blind to squareness errors. Moreover, these alternative methods require significantly more time to complete a machine qualification.

## State-of-the-art method



IBS's machine tool qualification systems offer several advantages over laser interferometers:

- **Easy set-up and operation**, both by the machine operator. The system can be installed directly on the machine tool without the need for complex alignment or calibration
- **Rapid measurements**, measurements are done in real-time in minutes, which speed up the machine qualification process immensely
- **Wide measurement range**, including linear and rotary motion, with quality report, status and trend data.

## More benefits of IBS's machine qualification systems

- Quick periodic accuracy checks **give confidence** that the machine (and the product) is within tolerances
- Less downtime after maintenance, shift or crash. You can **quickly resume production**
- Less need to check your products on a CMM. You have **more control** over your production process on-site.
- The measuring report indicates the parameters for improving pivot line offsets and squareness errors, giving you the option to **optimize the accuracy of the machine.**

# Understanding Machine Qualification



Our machine-integrated, workshop robust **Inspector systems** provide rapid and automatic qualification of cutting position, rotary table characteristics or spindle behavior.

Our **Analyzer systems** offer in-depth measurement and diagnostics.



**Inspector Series**



---



**Analyzer Series**



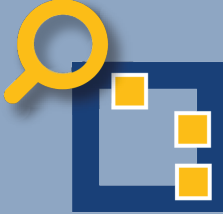

## Inspector Series

- **Speed:** Machine inspection in minutes to micron accuracy and below
- **Simplicity:** Automated measurement to ISO standards
- **Assurance:** Digital quality reporting and interactive history
- **Control:** Tolerance setting and optional compensation

	LINEAR AXIS	LINEAR & ROTARY AXIS	SPINDLE
 Inspector Series			

## Analyzer Series

- **Power:** In-depth measurement and diagnostics
- **Flexibility:** User defined machine analysis
- **Accuracy:** From microns to nm
- **Speed:** Complex measurements executed in minutes

	LINEAR AXIS	LINEAR & ROTARY AXIS	SPINDLE
 Analyzer Series			



# Understanding Machine Qualification



The **Position Inspector** is designed to provide a rapid, automatic method for calibration of machine **linear axes**. Measurements are made according to international standards (ISO 230). Results are presented instantaneously in a digital quality report as well as an interactive history function.



# Understanding Machine Qualification



The **Position Analyzer** is designed for applications where machine size or layout requires a specially defined measurement artefact. The system provides measurements of the machine's 3D positioning and straightness errors according to ISO 230, with comprehensive diagnostic capability.



# Understanding Machine Qualification



The **Rotary Inspector** provides a revolutionary method to measure and correct the **full 5-axis kinematic performance**. Rapid measurement (<1 min), based on standard ISO measurements, allows for tracking of error development over time (thermal distortion). A digital quality report shows the KPIs.

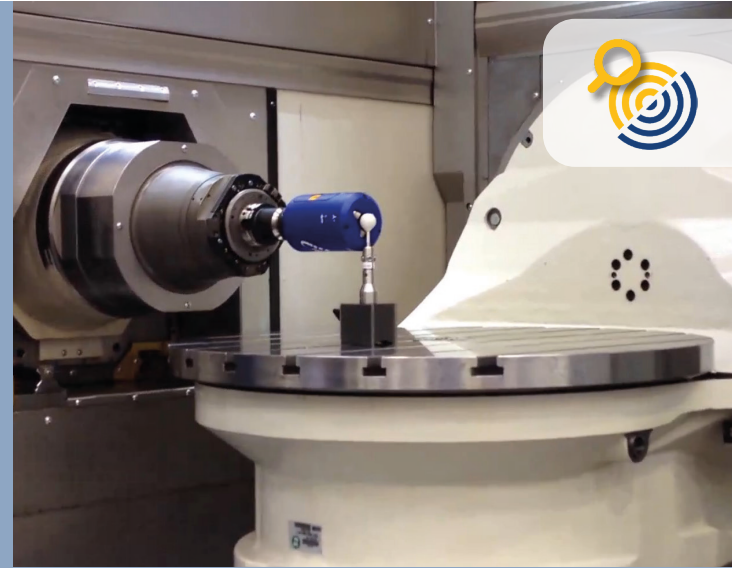

# Understanding Machine Qualification



The **Rotary Analyzer** is designed for machine specific tests and in-depth analysis. It can be easily programmed to perform a range of static or dynamic user defined tests including ISO standard measurements. Customised **multi-axis** machine acceptance tests can be developed and measurements completed in minutes.



# Understanding Machine Qualification



The **Integrated Spindle Inspector** offers accuracy, speed and an intelligent measurement solution easily integrated into your spindle and your control systems. Sensors are built-in and simultaneously measure machine spindle runout in the X, Y, and Z directions. Axial and radial error motions are measured at 15 kHz with up to 5 sensors and 65 nm resolution.

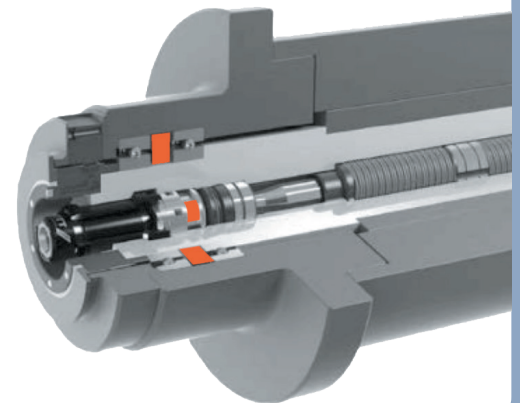
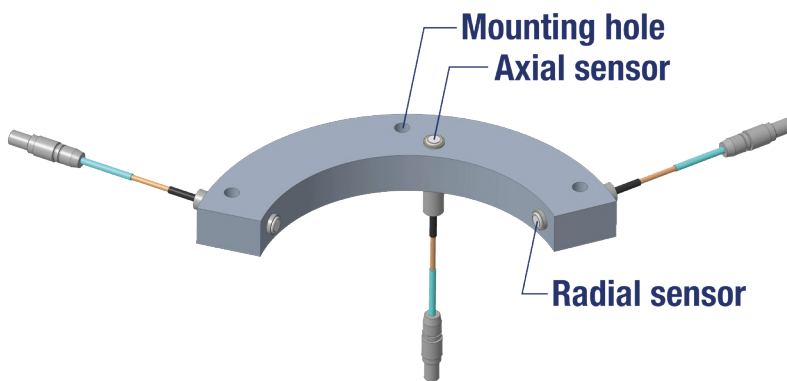

# Understanding Machine Qualification



Our **Spindle Analyzer** systems offer in-depth spindle accuracy and performance assessment at the nano level.

- **Spindle Check Analyzer (SCA)** for shop floor use offers regular and rapid inspection.
- **Spindle Error Analyzer (SEA)** for machine tool builders offers additional measurement and analysis options for further detailed assessment.



**Spindle Check Analyzer**



**Spindle Error Analyzer**

# Understanding Machine Qualification



Do you want to know more about our **Machine Qualification Systems**, the different series and the advantages?



Visit our website,  
<https://www.ibspe.com/machine-qualification>,

read our brochure,  
[Machine Tool Inspection and Analyzer Solutions](#),

or contact our [experts](#).